

OPERATOR'S MANUAL

INCLUDING: OPERATION, INSTALLATION & MAINTENANCE

PD10X-X

PE10X-X

RELEASED: 3-11-04
 REVISED: 10-7-04
 (REV. 03)

1" DIAPHRAGM PUMP 1:1 RATIO (METALLIC)



**READ THIS MANUAL CAREFULLY BEFORE INSTALLING,
 OPERATING OR SERVICING THIS EQUIPMENT.**

It is the responsibility of the employer to place this information in the hands of the operator. Keep for future reference.

SERVICE KITS

Refer to Model Chart to match the pump material options.
 637397 for Air Section repair (see page 6).
 637401-XX for Fluid Section repair (see page 4). NOTE: This kit also
 contains several air motor seals which will need to be replaced.
 637395-X Major Air Valve Assembly (see page 7).

PUMP DATA

Models See Model Description Chart for "-XXX".
Pump Type Metallic Air Operated Double Diaphragm
Material See Model Description Chart.
Weight ... PX10R-XAX-XXX 18.3 lbs (8.3 kgs)
 PX10R-XCX-XXX 35.2 lbs (16.0 kgs)
 PX10R-XSX-XXX 38.2 lbs (17.3 kgs)
 add 6.1 lbs (2.75 kg) for Aluminum air motor section
 add 12.9 lbs (5.84 kg) for Stainless Steel air motor section

Maximum Air Inlet Pressure 120 p.s.i.g. (8.3 bar)
Maximum Material Inlet Pressure 10 p.s.i.g. (0.69 bar)
Maximum Outlet Pressure 120 p.s.i.g. (8.3 bar)
Maximum Flow Rate (flooded inlet) 52.2 g.p.m. (197.6 l.p.m.)
Displacement / Cycle @ 100 p.s.i.g. ... 0.232 gal. (0.88 lit.)
Maximum Particle Size 1/8" dia. (3.3 mm)
Maximum Temperature Limits (Diaphragm / Ball / Seat material)

Hytre [®]	-20° - 150° F (-29° - 66° C)
Nitrile	10° - 180° F (-12° - 82° C)
Polypropylene	35° - 150° F (2° - 66° C)
Santoprene [®]	-40° - 225° F (-40° - 107° C)
T.F.E. (Teflon [®])	40° - 225° F (4° - 107° C)
Viton [®]	-40° - 350° F (-40° - 177° C)

Dimensional Data see page 8
Mounting Dimension 4" x 6.25" (101.6 mm x 158.8 mm)
Noise Level @ 70 p.s.i., 60 c.p.m. 80.6 db(A)^①

① The pump sound pressure levels published here have been updated to an Equivalent Continuous Sound Level (L_{Aeq}) to meet the intent of ANSI S1.13-1971, CAGI-PNEU-RQP S5.1 using four microphone locations.

NOTICE: All possible options are shown in the chart, however, certain combinations may not be recommended, consult a representative or the factory if you have questions concerning availability.

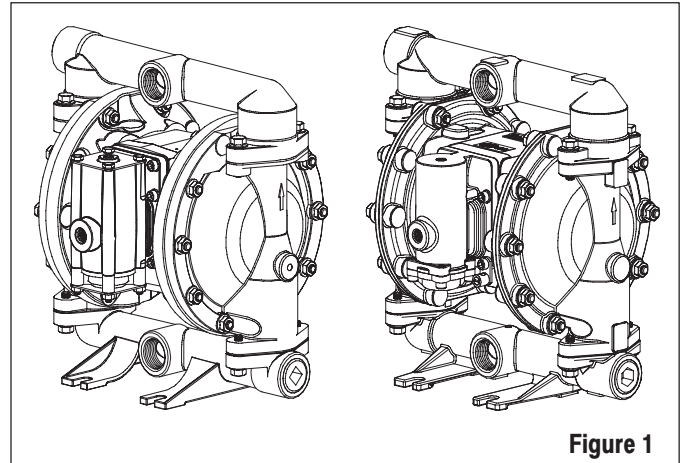

Figure 1

MODEL DESCRIPTION CHART

		P X 10 X - X X X - X X X					
ELECTRONIC INTERFACE		D - None E - Available					
CENTER SECTION MATERIAL		A - Aluminum R - Polypropylene S - Stainless Steel					
FLUID CONNECTION		A - 1 - 11-1/2 N.P.T.F. - 1 B - 1 - 11 BSP					
FLUID CAPS & MANIFOLD MATERIAL		A - Aluminum C - Cast Iron S - Stainless Steel					
HARDWARE MATERIAL		P - Plated Steel S - Stainless Steel					
SEAT MATERIAL		A - Santoprene G - Nitrile C - Hytre H - Hard 440 Stainless Steel E - Carbon Steel L - Hastelloy - C F - Aluminum S - 316 Stainless Steel					
BALL MATERIAL		A - Santoprene S - 316 Stainless Steel C - Hytre T - Teflon G - Nitrile V - Viton					
DIAPHRAGM MATERIAL		A - Santoprene M - Medical Grade Santoprene C - Hytre V - Viton G - Nitrile T - Teflon / Santoprene					
FLUID SECTION SERVICE KIT SELECTION		PX10X - XXX - X X X					
EXAMPLE: MODEL # PD10A-ASP-AAA		637401 - X X X					
FLUID SECTION SERVICE KIT # 637401-AA		BALL <input type="checkbox"/> DIAPHRAGM <input type="checkbox"/>					

OPERATING AND SAFETY PRECAUTIONS

READ, UNDERSTAND, AND FOLLOW THIS INFORMATION TO AVOID INJURY AND PROPERTY DAMAGE.



⚠ WARNING EXCESSIVE AIR PRESSURE. Can cause personal injury, pump damage or property damage.

- Do not exceed the maximum inlet air pressure as stated on the pump model plate.
- Be sure material hoses and other components are able to withstand fluid pressures developed by this pump. Check all hoses for damage or wear. Be certain dispensing device is clean and in proper working condition.

⚠ WARNING STATIC SPARK. Can cause explosion resulting in severe injury or death. Ground pump and pumping system.

- Sparks can ignite flammable material and vapors.
- The pumping system and object being sprayed must be grounded when it is pumping, flushing, recirculating or spraying flammable materials such as paints, solvents, lacquers, etc. or used in a location where surrounding atmosphere is conducive to spontaneous combustion. Ground the dispensing valve or device, containers, hoses and any object to which material is being pumped.
- Secure pump, connections and all contact points to avoid vibration and generation of contact or static spark.
- Consult local building codes and electrical codes for specific grounding requirements.
- After grounding, periodically verify continuity of electrical path to ground. Test with an ohmmeter from each component (e.g., hoses, pump, clamps, container, spray gun, etc.) to ground to insure continuity. Ohmmeter should show 0.1 ohms or less.
- Submerge the outlet hose end, dispensing valve or device in the material being dispensed if possible. (Avoid free streaming of material being dispensed.)
- Use hoses incorporating a static wire.
- Use proper ventilation.
- Keep inflammables away from heat, open flames and sparks.
- Keep containers closed when not in use.

⚠ WARNING Pump exhaust may contain contaminants. Can cause severe injury. Pipe exhaust away from work area and personnel.

- In the event of a diaphragm rupture, material can be forced out of the air exhaust muffler.
- Pipe the exhaust to a safe remote location when pumping hazardous or inflammable materials.
- Use a grounded 3/8" minimum i.d. hose between the pump and the muffler.

⚠ WARNING HAZARDOUS PRESSURE. Can result in serious injury or property damage. Do not service or clean pump, hoses or dispensing valve while the system is pressurized.

- Disconnect air supply line and relieve pressure from the system by opening dispensing valve or device and / or carefully and slowly loosening and removing outlet hose or piping from pump.

⚠ WARNING HAZARDOUS MATERIALS. Can cause serious injury or property damage. Do not attempt to return a pump to the factory or service center that contains hazardous material. Safe handling practices must comply with local and national laws and safety code requirements.

- Obtain Material Safety Data Sheets on all materials from the supplier for proper handling instructions.

⚠ WARNING EXPLOSION HAZARD. Models containing aluminum wetted parts cannot be used with III.-Trichloroethane, Methylene Chloride or other Halogenated Hydrocarbon solvents which may react and explode.

- Check pump motor section, fluid caps, manifolds and all wetted parts to assure compatibility before using with solvents of this type.

⚠ WARNING MISAPPLICATION HAZARD. Do not use models containing aluminum wetted parts with food products for human consumption. Plated parts can contain trace amounts of lead.

⚠ CAUTION Verify the chemical compatibility of the pump wetted parts and the substance being pumped, flushed or recirculated. Chemical compatibility may change with temperature and concentration of the chemical(s) within the substances being pumped, flushed or circulated. For specific fluid compatibility, consult the chemical manufacturer.

⚠ CAUTION Maximum temperatures are based on mechanical stress only. Certain chemicals will significantly reduce maximum safe operating temperature. Consult the chemical manufacturer for chemical compatibility and temperature limits. Refer to PUMP DATA on page 1 of this manual.

⚠ CAUTION Be certain all operators of this equipment have been trained for safe working practices, understand it's limitations, and wear safety goggles / equipment when required.

⚠ CAUTION Do not use the pump for the structural support of the piping system. Be certain the system components are properly supported to prevent stress on the pump parts.

- Suction and discharge connections should be flexible connections (such as hose), not rigid piped, and should be compatible with the substance being pumped.

⚠ CAUTION Prevent unnecessary damage to the pump. Do not allow pump to operate when out of material for long periods of time.

- Disconnect air line from pump when system sits idle for long periods of time.

⚠ CAUTION Use only genuine ARO replacement parts to assure compatible pressure rating and longest service life.

NOTICE RE-TORQUE ALL FASTENERS BEFORE OPERATION. Creep of housing and gasket materials may cause fasteners to loosen. Re-torque all fasteners to insure against fluid or air leakage

⚠ WARNING = Hazards or unsafe practices which could result in severe personal injury, death or substantial property damage.

⚠ CAUTION = Hazards or unsafe practices which could result in minor personal injury, product or property damage.

NOTICE = Important installation, operation or maintenance information.

GENERAL DESCRIPTION

The ARO Diaphragm Pump offers high volume delivery even at low air pressure and a broad range of material compatibility options available. Refer to the model and option chart. ARO pumps feature stall resistant design, modular air motor / fluid sections.

Air operated double diaphragm pumps utilize a pressure differential in the air chambers to alternately create suction and positive fluid pressure in the fluid chambers, ball checks insure a positive flow of fluid.

Pump cycling will begin as air pressure is applied and it will continue to pump and keep up with the demand. It will build and maintain line pressure and will stop cycling once maximum line pressure is reached (dispensing device closed) and will resume pumping as needed.

AIR AND LUBE REQUIREMENTS

⚠ WARNING EXCESSIVE AIR PRESSURE. Can cause pump damage, personal injury or property damage.

- A filter capable of filtering out particles larger than 50 microns should be used on the air supply. There is no lubrication required other than the “O” ring lubricant which is applied during assembly or repair.
- If lubricated air is present, make sure that it is compatible with the Nitrile seals in the air motor section of the pump.

INSTALLATION

- Verify correct model / configuration prior to installation.
- Retorque all external fasteners per specifications prior to start up.
- Pumps are tested in water at assembly. Flush pump with compatible fluid prior to installation.
- When the diaphragm pump is used in a forced-feed (flooded inlet) situation, it is recommended that a “Check Valve” be installed at the air inlet.
- Material supply tubing should be at least the same diameter as the pump inlet manifold connection.
- Material supply hose must be reinforced, non-collapsible type compatible with the material being pumped.
- Piping must be adequately supported. Do not use the pump to support the piping.
- Use flexible connections (such as hose) at the suction and discharge. These connections should not be rigid piped and must be compatible with the material being pumped.
- Secure the diaphragm pump legs to a suitable surface (level and flat) to insure against damage by vibration.
- Pumps that need to be submersed must have both wet and non-wet components compatible with the material being pumped.
- Submersed pumps must have exhaust pipe above liquid level. Exhaust hose must be conductive and grounded.
- Flooded suction inlet pressure must not exceed 10 p.s.i.g. (0.69 bar).

OPERATING INSTRUCTIONS

- Always flush the pump with a solvent compatible with the material being pumped if the material being pumped is subject to “setting up” when not in use for a period of time.
- Disconnect the air supply from the pump if it is to be inactive for a few hours.

PARTS AND SERVICE KITS

Refer to the part views and descriptions as provided on page 4 through 7 for parts identification and Service Kit information.

- Certain ARO “Smart Parts” are indicated which should be available for fast repair and reduction of down time.
- Service kits are divided to service two separate diaphragm pump functions: 1. AIR SECTION, 2. FLUID SECTION. The FLUID SECTION is divided further to match typical part MATERIAL OPTIONS.

MAINTENANCE

- Provide a clean work surface to protect sensitive internal moving parts from contamination from dirt and foreign matter during service disassembly and reassembly.
- Keep good records of service activity and include pump in preventive maintenance program.
- Before disassembling, empty captured material in the outlet manifold by turning the pump upside down to drain material from the pump.

FLUID SECTION DISASSEMBLY

1. Remove (61) outlet manifold, (60) inlet manifold.
2. Remove (22) balls, (19) “O” rings (if applicable) and (21) seats.
3. Remove (15) fluid caps.
NOTE: Only Teflon diaphragm models use a primary diaphragm (7) and a backup diaphragm (8). Refer to the auxiliary view in the Fluid Section illustration.
4. Remove the (6) diaphragm washer, (7) or (7/8) diaphragms, and (5) backup washer.

NOTE: Do not scratch or mar the surface of (1) diaphragm rod.

FLUID SECTION REASSEMBLY

- Reassemble in reverse order. Refer to the torque requirements on page 5.
- Clean and inspect all parts. Replace worn or damaged parts with new parts as required.
- Lubricate (1) diaphragm rod and (144) “U” cup with Lubriplate FML-2 grease (94276 grease packet is included in service kit).
- For models with Teflon diaphragms: Item (8) Santoprene diaphragm is installed with the side marked “AIR SIDE” towards the pump center body. Install the Teflon diaphragm (7) with the side marked “FLUID SIDE” towards the (15) fluid cap.
- Re-check torque settings after pump has been re-started and run a while.

PARTS LIST / PX10X-X FLUID SECTION

★ 637401-XX FLUID SECTION SERVICE KITS INCLUDE: BALLS (see Ball Option, refer to -XX in Service Kit chart below), DIAPHRAGMS (see Diaphragm Option, refer to -XX in Service Kit chart below), and items 19, 70, 144, 175 and 180 (listed below) plus 174 and 94276 Lubriplate FML-2 grease (page 6).

SEAT OPTIONS PX10X-XXX-XXX

"21"		★ "19"		★ "33"		"21"		★ "19"		★ "33"			
-XXX	Seat (4)	[Mtl]	Gasket (4)	[Mtl]	Gasket (4)	[Mtl]	-XXX	Seat (4)	[Mtl]	Gasket (4)	[Mtl]	Gasket (4)	[Mtl]
-AXX	96152-A	[SP]	-----	---	-----	---	-HGX	94706	[SH]	Y325-225	[B]	Y325-220	[B]
-CXX	96152-C	[H]	-----	---	-----	---	-HSX	94706	[SH]	93282	[T]	93281	[T]
-EAX	96158	[C]	93280	[E]	93279	[E]	-HTX	94706	[SH]	93282	[T]	93281	[T]
-EGX	96158	[C]	Y325-225	[B]	Y325-220	[B]	-HVX	94706	[SH]	Y327-225	[V]	Y327-220	[V]
-ETX	96158	[C]	93282	[T]	93281	[T]	-LTX	95836	[Ha]	93282	[T]	93281	[T]
-EVX	96158	[C]	Y327-225	[V]	Y327-220	[V]	-LVX	95836	[Ha]	Y327-225	[V]	Y327-220	[V]
-FTX	96156	[A]	93282	[T]	93281	[T]	-SAX	96151	[SS]	93280	[E]	93279	[E]
-FVX	96156	[A]	Y327-225	[V]	Y327-220	[V]	-SGX	96151	[SS]	Y325-225	[B]	Y325-220	[B]
-GXX	96152-G	[B]	-----	---	-----	---	-SSX	96151	[SS]	93282	[T]	93281	[T]
-HAX	94706	[SH]	93280	[E]	93279	[E]	-STX	96151	[SS]	93282	[T]	93281	[T]
-HCX	94706	[SH]	Y327-225	[V]	Y327-220	[V]	-SVX	96151	[SS]	Y327-225	[V]	Y327-220	[V]

BALL OPTIONS PX10X-XXX-XXX

★ "22" (1-1/4" dia.)			
-XXX	Ball	Qty	[Mtl]
-XAX	93278-A	(4)	[SP]
-XCX	93278-C	(4)	[H]
-XGX	93278-2	(4)	[B]
-XSX	92408	(4)	[SS]
-XTX	93278-4	(4)	[T]
-XVX	93278-3	(4)	[V]

DIAPHRAGM OPTIONS PX10X-XXX-XXX

★ Service Kit		★ "7" / "8"		
-XXX	-XX = (Ball) -XX = (Diaphragm)	Diaphragm	Qty	[Mtl]
-XXA	637401-XA	96267-A	(2)	[SP]
-XXC	637401-XC	96267-C	(2)	[H]
-XXG	637401-XG	96267-G	(2)	[B]
-XXM	637401-XM	96267-M	(2)	[MSP]
-XXT	637401-XT	96146-T / 96145-A	(2)	[T / SP]
-XXV	637401-XV	95989-3	(2)	[V]

CENTER SECTION OPTIONS PX10X-XXX-XXX

Item	Description (size)	Qty	PD10A-X			PD10R-X			PD10S-X			PE10S-X		
			Part No.	Part No.	[Mtl]	Part No.	Part No.	[Mtl]	Part No.	Part No.	[Mtl]	Part No.	Part No.	[Mtl]
28	Washer (8.5 mm i.d.)	(8)	-----	-----	---	96217	96217	[SS]	-----	-----	---	-----	-----	---
43	Ground Lug	(1)	93004	93004	[Co]	-----	-----	---	93004	93004	[Co]	-----	-----	---
68	Air Cap	(1)	95994-2	95994-4	[A]	96104-1	96104-3	[P]	96007-1	96007-3	[SS]	-----	-----	---
69	Air Cap	(1)	95994-1	95994-3	[A]	96104-2	96104-4	[P]	96007-2	96007-4	[SS]	-----	-----	---
74	Pipe Plug (1/4 - 18 N.P.T. x 7/16")	(2)	-----	Y17-51-S	[SS]	-----	93832-3	[K]	-----	-----	---	-----	Y17-51-S	[SS]
76	Pipe Plug (1/8 - 27 N.P.T. x 0.27")	(1)	-----	Y17-50-S	[SS]	-----	Y17-50-S	[SS]	-----	-----	---	-----	Y17-50-S	[SS]
131	Screw (M8 x 1.25 - 6g x 95 mm)	(4)	96001	96001	[C]	-----	-----	---	96001	96001	[C]	-----	-----	---
	(M8 x 1.25 - 6g x 100 mm)	(4)	-----	-----	---	96216	96216	[SS]	-----	-----	---	-----	-----	---
✓ 180	Washer	(4)	96006	96006	[Co]	-----	-----	---	96006	96006	[Co]	-----	-----	---
★ ✓	"O" Ring (2.5 mm x 12 mm o.d.)	(8)	-----	-----	---	96292	96292	[B]	-----	-----	---	-----	-----	---

MANIFOLD / FLUID CAP MATERIAL OPTIONS PX10X-XXX-XXX

Item	Description (size)	Qty	PX10X-XAX-		PX10X-XCX-		PX10X-XSX-	
			Part No.	[Mtl]	Part No.	[Mtl]	Part No.	[Mtl]
5	Backup Washer	(2)	95990-3	[C]	95990-3	[C]	95990-1	[SS]
6	Diaphragm Washer	(2)	95990-3	[C]	95990-3	[C]	95990-1	[SS]
9	Washer (.505" l.d.)	(2)	93189-1	[SS]	93189-1	[SS]	93189-1	[SS]
14	Screw (M12 x 1.75 - 6g x 25 mm)	(2)	95997	[SS]	95997	[SS]	95997	[SS]
15	Fluid Cap	(2)	95935	[A]	95831	[C]	96010	[SS]
60	Inlet Manifold	(1)	95936- ◆	[A]	95829- ◆	[C]	96008- ◆	[SS]
61	Outlet Manifold	(1)	95960- ◆	[A]	95830- ◆	[C]	96009- ◆	[SS]
63	Pipe Plug (1 N.P.T.) (R1)	(2)	Y17-125	[A]	Y17-55-S	[SS]	Y17-55-S	[SS]
			96160-2	[A]	96160-1	[SS]	96160-1	[SS]

MATERIAL CODE	
[A]	= Aluminum
[B]	= Nitrile
[C]	= Carbon Steel
[CI]	= Cast Iron
[Co]	= Copper
[E]	= E.P.R.
[H]	= Hytrel
[Ha]	= Hastelloy-C
[K]	= PVDF (Kynar®)
[MSP]	= Medical Grade Santoprene
[P]	= Polypropylene
[SH]	= Hard Stainless Steel
[SP]	= Santoprene
[SS]	= Stainless Steel
[T]	= Teflon
[V]	= Viton

◆ For N.P.T.F. thread models (PX10X-AXX-XXX), use "-1"

◆ For BSP thread models (PX10X-BXX-XXX), use "-2"

EXTERNAL HARDWARE OPTIONS PX10X-XXX-XXX

Item	Description (size)	Qty	PX10X-XXP-		PX10X-XXS-	
			Part No.	[Mtl]	Part No.	[Mtl]
26	Screw (M8 x 1.25 - 6g x 30 mm)	(8)	95880-1	[C]	95880	[SS]
27	Bolt (M8 x 1.25 - 6g x 40 mm)	(20)	95896-1	[C]	95896	[SS]
29	Hex Flange Nut (M8 x 1.25 - 6h)	(20)	95879-1	[C]	95879	[SS]

COMMON PARTS

Item	Description (size)	Qty	Part No.	Mtl
1	Rod	(1)	95995	[C]
★ ✓ 70	Gasket	(2)	95843	[B]
★ ✓ 144	"U" Cup (3/16" x 1-1/8" o.d.)	(2)	Y186-49	[B]
★ ✓ 175	"O" Ring (3/32" x 13/16" o.d.)	(2)	Y325-114	[B]
195	Nut (M8 x 1.25 - 6h)	(4)	96005	[SS]

✓ Air Section Service Kit Parts, see page 6.

PARTS LIST / PX10X-X FLUID SECTION

COLOR CODE		
MATERIAL	DIAPHRAGM COLOR	BALL COLOR
HYTREL	Cream	Cream
NITRILE	Black	Red (+)
SANTOPRENE	Tan	Tan
SANTOPRENE (Backup)	Green	N / A
TEFLON	White	White
VITON	Yellow (-)	Yellow (+)
	(-) Dash	(+) Dot

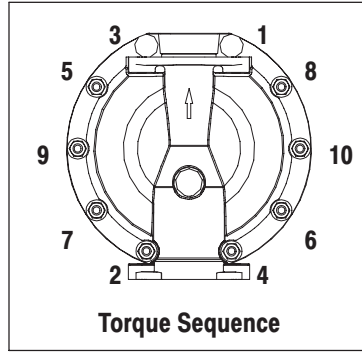

TORQUE REQUIREMENTS

NOTE: DO NOT OVERTIGHTEN FASTENERS.
ALL FASTENERS ARE METRIC.
 (14) screw, tighten to 25 - 30 ft lbs (33.9 - 40.7 Nm).
 (26) screws, 20 - 25 ft lbs (27.1 - 33.9 Nm).
 (29) nuts, 15 - 20 ft lbs (20.3 - 27.1 Nm).
 (131) screws, 12 - 17 ft lbs (16.3 - 23.0 Nm).

LUBRICATION / SEALANTS

- ☆ Apply Lubriplate FML-2 Grease to all "O" rings, "U" Cups & mating parts.
- ♣ Apply Loctite 242 to threads at assembly.
- Apply Teflon tape to threads at assembly.
- Apply Loctite 271 to threads at assembly.
- ⊠ Apply anti-seize compound to threads at assembly.

◇ Lubriplate FML-2 is a white food grade petroleum grease.

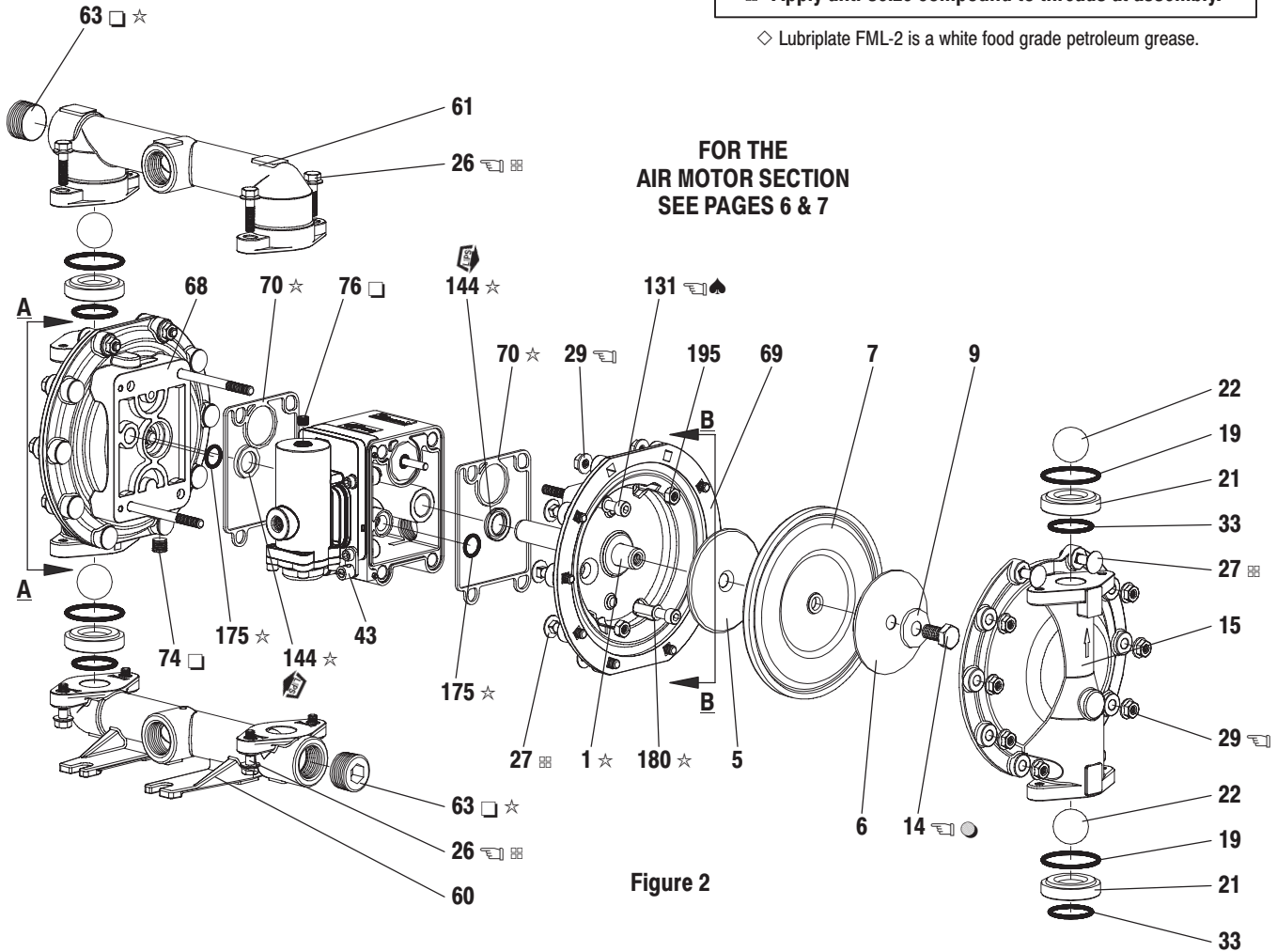

FOR THE AIR MOTOR SECTION SEE PAGES 6 & 7

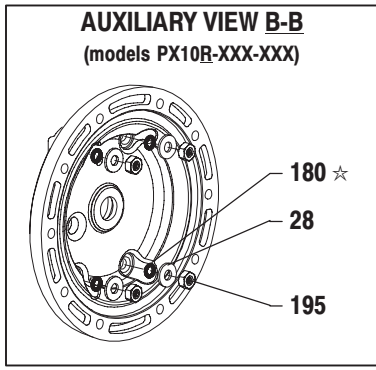
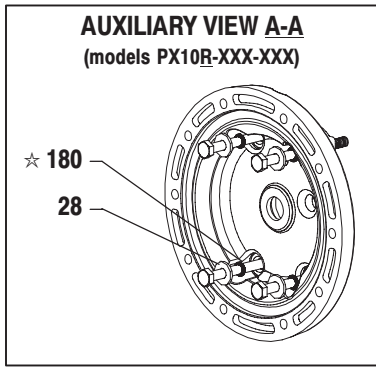
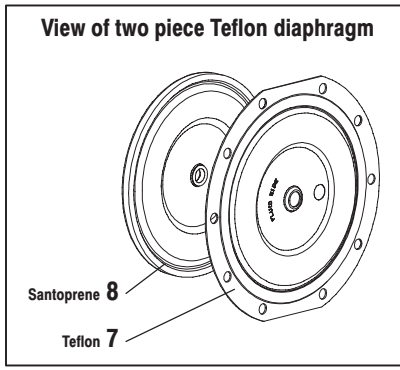

PARTS LIST / PX10X-X AIR SECTION

✓ Indicates parts included in 637397 Air Section Service Kit shown below and items (70), (144), (175) and (180) shown on page 4.

AIR MOTOR PARTS

Item	Description (size)	Qty	Part No.	[Mtl]
101	Center Body (PX10A-X)	(1)	95888	[A]
	(PX10R-X)	(1)	95970	[P]
	(PX10S-X)	(1)	95901	[SS]
103	Bushing	(1)	96000	[D]
105	Screw (M6 x 1 - 6g)			
	(PX10A-X and PX10S-X) (16 mm long)	(4)	95991	[SS]
	(PX10R-X) (130 mm long)	(4)	95886	[SS]
107	End Plate (PX10R-X only)	(2)	95840	[SS]
111	Spool (PX10A-X and PX10S-X)	(1)	95835	[D]
	(PX10R-X)	(1)	96293	[D]
118	Actuator Pin	(2)	95999	[SS]
121	Sleeve	(2)	95123	[D]
128	Pipe Plug (1/8 - 27 N.P.T. x 0.27") (PX10A-X and PX10S-X only)	(1)	Y17-50-S	[SS]
✓ 132	Gasket (PX10A-X and PX10S-X)	(1)	96170	[B]
	(PX10R-X)	(1)	95841	[B]
133	Washer (1/4") (PX10A-X)	(3)	Y117-416-C	[C]
	(M6) (PX10R-X)	(6)	95931	[SS]
	(1/4") (PX10S-X)	(3)	Y14-416-T	[SS]
134	Screw (M6 x 1 - 6g x 20 mm) (PX10R-X)	(6)	95887	[SS]
	(PX10A-X and PX10S-X)	(4)	95887	[SS]
135	Valve Block (PD10A-X)	(1)	95942-3	[Z]
	(PD10R-X)	(1)	96174-1	[P]
	(PD10S-X)	(1)	95939-3	[SS]
	(PE10A-X)	(1)	95942-4	[Z]
	(PE10R-X)	(1)	96174-2	[P]
	(PE10S-X)	(1)	95939-4	[SS]

★ Fluid Section Service Kit Parts, see page 4.

Item	Description (size)	Qty	Part No.	[Mtl]
136	End Cap (PX10A-X)	(1)	95941	[Z]
	(PX10R-X)	(1)	95833	[P]
	(PX10S-X)	(1)	95938	[SS]
✓ 137	Gasket	(1)	95844	[B]
✓ 138	"U" Cup (3/16" x 1-5/8" o.d.)	(1)	Y186-53	[B]
✓ 139	"U" Cup (3/16" x 1-1/8" o.d.)	(1)	Y186-49	[B]
140	Valve Insert	(1)	95838	[AO]
141	Valve Plate	(1)	95885	[AO]
✓ 166	Gasket (PX10A-X and PX10S-X)	(1)	96171	[B]
	(PX10R-X)	(1)	96004	[B]
✓ 167	Pilot Piston (includes 168 and 169)	(1)	67164	[D]
168	"O" Ring (3/32" x 5/8" o.d.)	(2)	94433	[U]
169	"U" Cup (1/8" x 7/8" o.d.)	(1)	Y240-9	[B]
170	Piston Sleeve	(1)	94081	[Br]
✓ 171	"O" Ring (3/32" x 1-1/8" o.d.)	(1)	Y325-119	[B]
✓ 172	"O" Ring (1/16" x 1-1/8" o.d.)	(1)	Y325-22	[B]
✓ 173	"O" Ring (3/32" x 1-3/8" o.d.)	(2)	Y325-123	[B]
★ ✓ 174	"O" Ring (1/8" x 1/2" o.d.)	(2)	Y325-202	[B]
✓ 176	Diaphragm (check valve)	(2)	95845	[SP]
181	Roll Pin (5/32" o.d. x 1/2" long)	(4)	Y178-52-S	[SS]
✓ 200	Gasket (PX10A-X and PX10S-X)	(1)	96172	[B]
	(PX10R-X)	(1)	95842	[B]
201	Muffler	(1)	93139	[P]
233	Adapter Plate	(1)	95832	[P]
236	Nut (M6 x 1 - 6g) (PX10R-X only)	(4)	95924	[SS]
★ ✓	Lubriplate FML-2 Grease	(1)	94276	
	Lubriplate Grease Packets (10)		637308	

AIR MOTOR SECTION SERVICE

Service is divided into two parts - 1. Pilot Valve, 2. Major Valve.

GENERAL REASSEMBLY NOTES:

- Air Motor Section Service is continued from Fluid Section repair.
- Inspect and replace old parts with new parts as necessary. Look for deep scratches on surfaces, and nicks or cuts in "O" rings.
- Take precautions to prevent cutting "O" rings upon installation.
- Lubricate "O" rings with Lubriplate FML-2 grease.
- Do not over-tighten fasteners, refer to torque specification block on view.
- Re-torque fasteners following restart.
- SERVICE TOOLS - To aid in the installation (168) "O" rings onto the (167) pilot piston, use Tool # 204130-T, available from Aro.

PILOT VALVE DISASSEMBLY

1. A light tap on (118) should expose the opposite (121) sleeve, (167) pilot piston and other parts.
2. Remove (170) sleeve, inspect inner bore of sleeve for damage.

PILOT VALVE REASSEMBLY

1. Clean and lubricate parts not being replaced from service kit.
2. Install new (171 and 172) "O" rings, replace (170) sleeve.
3. Install new (168) "O" rings and (169) seal - Note the lip direction. Lubricate and replace (167).

4. Reassemble remaining parts, replace (173 and 174) "O" rings.

MAJOR VALVE DISASSEMBLY

1. Remove (135) valve block and (233) adapter plate, exposing (132 and 166) gaskets and (176) checks.
2. Remove (233) adapter plate, releasing (140) valve insert, (141) valve plate, (200) gasket.
3. Remove (136) end cap and (137) gasket, releasing (111) spool.

MAJOR VALVE REASSEMBLY

1. Install new (138 and 139) "U" cups on (111) spool - **LIPS MUST FACE EACH OTHER.**
2. Insert (111) spool into (135) valve block.
3. Install (137) gasket on (136) end cap and assemble end cap to (135) valve block, securing with (107) end plates (where applicable) and (105) screws.
4. Install (140) valve insert and (141) valve plate into (135) valve block. NOTE: Assemble (140) valve insert with "dished" side toward (141) valve plate. Assemble (141) valve plate with part number identification toward (140) valve insert.
5. Assemble (200) gasket and (233) adapter plate to (135) valve block.
6. Assemble (132 and 166) gaskets and (176) checks to (101) body.
7. Assemble (135) valve block and components to (101) body, securing with (134) screws.

PARTS LIST / PX10X-X AIR SECTION

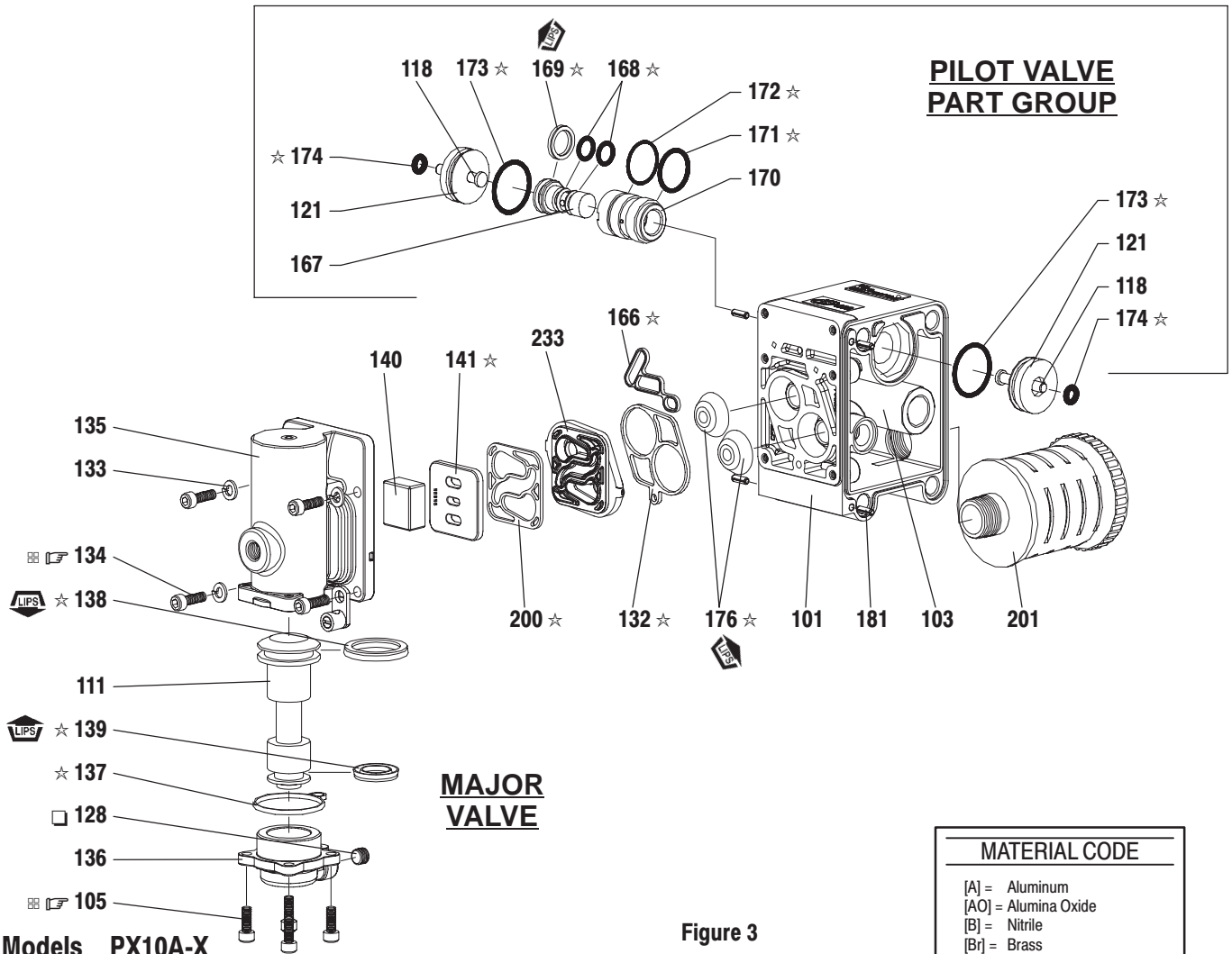

PILOT VALVE PART GROUP

MAJOR VALVE

MATERIAL CODE

[A]	Aluminum
[AO]	Alumina Oxide
[B]	Nitrile
[Br]	Brass
[C]	Carbon Steel
[D]	Acetal
[I]	Iron
[P]	Polypropylene
[SP]	Santoprene
[SS]	Stainless Steel
[U]	Polyurethane
[Z]	Zinc

Figure 3

Models **PX10A-X**
PX10S-X

Models **PX10R-X**

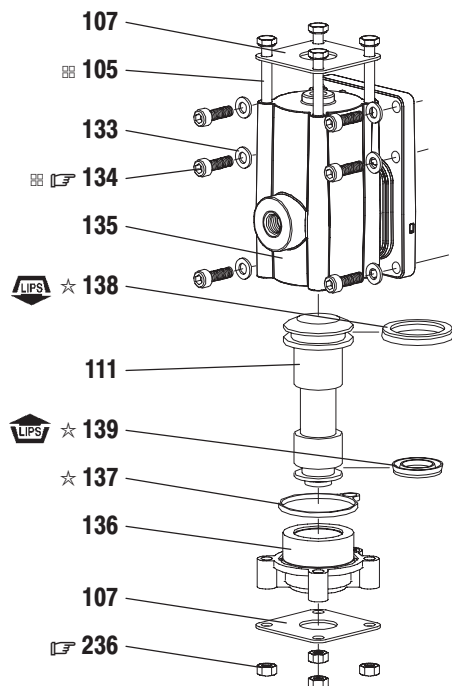

TORQUE REQUIREMENTS

**NOTE: DO NOT OVERTIGHTEN FASTENERS.
ALL FASTENERS ARE METRIC.**

PX10A-X and PX10S-X: Torque (105 and 134) screws to 40 - 50 in. lbs (4.5 - 5.6 Nm).
PX10R-X: Torque (134) screw and (236) nut to 35 - 40 in. lbs (4.0 - 4.5 Nm).

LUBRICATION / SEALANTS

- ★ Apply Lubriplate FML-2 Grease to "O" rings, "U" Cups & mating parts.
- Apply Teflon tape to threads at assembly.
- ▣ Apply anti-seize compound to threads at assembly.

A replacement Major Valve Service Assembly is available separately, which includes the following:

- 637395-1 for models PD10R-X: 105 (4), 107 (2), 111, 132, 135, 136, 137, 138, 139, 140, 141, 166, 176 (2), 200, 233 and 236 (4).
- 637395-2 for models PE10R-X: 76, 105 (4), 107 (2), 111, 132, 135, 136, 137, 138, 139, 140, 141, 166, 176 (2), 200, 233 and 236 (4).
- 637395-3 for models PD10A-X: 105 (4), 111, 128, 132, 135, 136, 137, 138, 139, 140, 141, 166, 176 (2), 200 and 233.
- 637395-4 for models PE10A-X: 76, 105 (4), 111, 128, 132, 135, 136, 137, 138, 139, 140, 141, 166, 176 (2), 200 and 233.
- 637395-5 for models PD10S-X: 105 (4), 111, 128, 132, 135, 136, 137, 138, 139, 140, 141, 166, 176 (2), 200 and 233.
- 637395-6 for models PE10S-X: 76, 105 (4), 111, 128, 132, 135, 136, 137, 138, 139, 140, 141, 166, 176 (2), 200 and 233.

TROUBLE SHOOTING

Product discharged from exhaust outlet.

- Check for diaphragm rupture.
- Check tightness of (14) diaphragm screw.

Air bubbles in product discharge.

- Check connections of suction plumbing.
- Check "O" rings between intake manifold and inlet side fluid caps.
- Check tightness of (14) diaphragm screw.

Motor blows air or stalls.

- Check (176) check valve for damage or wear.
- Check for restrictions in valve / exhaust.

Low output volume, erratic flow, or no flow.

- Check air supply.
- Check for plugged outlet hose.
- Check for kinked (restrictive) outlet material hose.
- Check for kinked (restrictive) or collapsed inlet material hose.
- Check for pump cavitation – suction pipe should be sized at least as large as the inlet thread diameter of the pump for proper flow if high viscosity fluids are being pumped. Suction hose must be a non-collapsing type, capable of pulling a high vacuum.
- Check all joints on the inlet manifolds and suction connections. These must be air tight.
- Inspect the pump for solid objects logged in the diaphragm chamber or the seat area.

DIMENSIONAL DATA

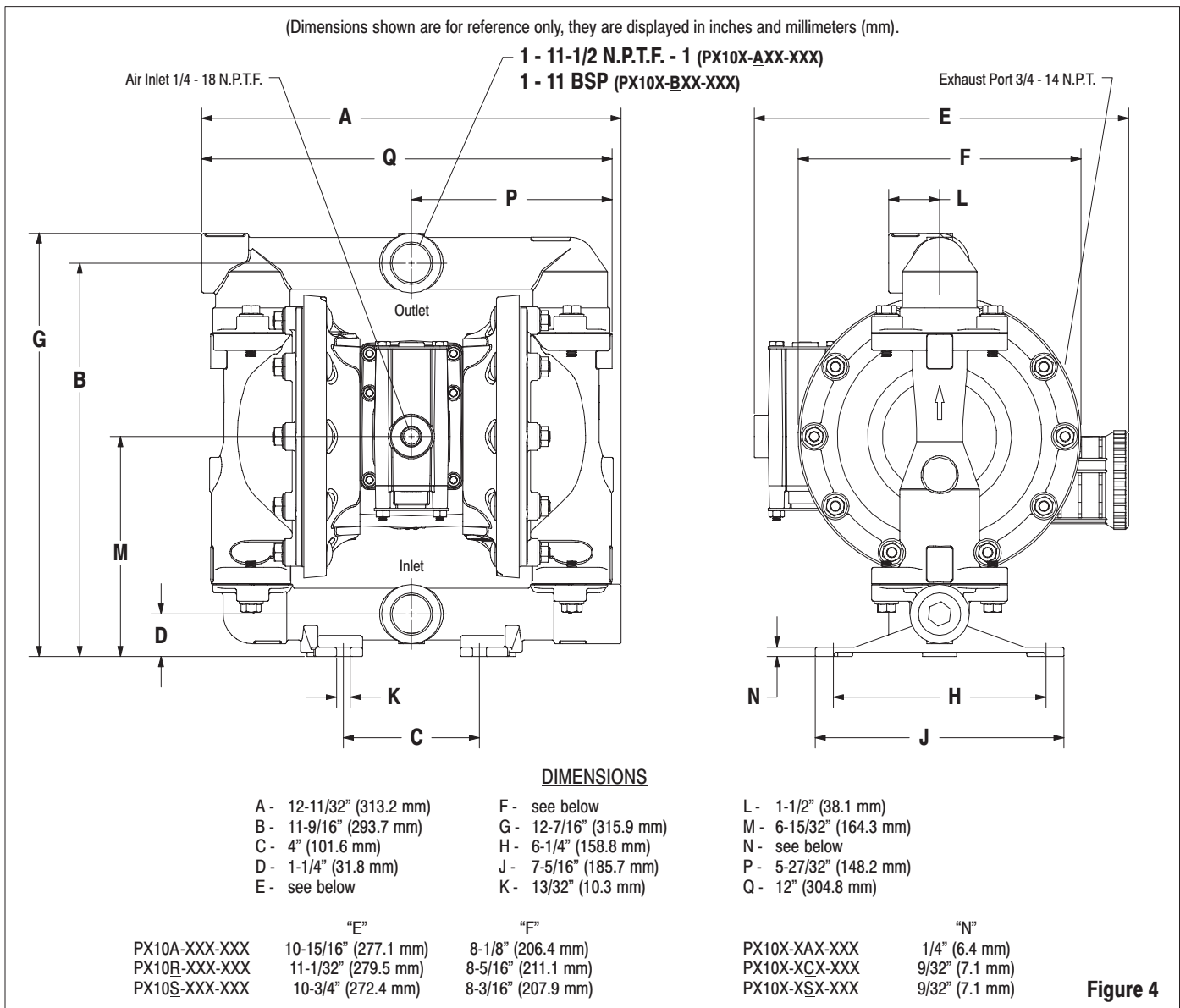

Figure 4