

SALES & ENGINEERING DATA

RATIO SERIES: **1:1**

FLUID P.S.I. RANGE: **20 - 120**

PM20X-CSS-XXX-A02 2" METALLIC DIAPHRAGM PUMP

RELEASED: 7-1-99
REVISED: 8-27-01
S-1087

DIMENSIONAL DATA

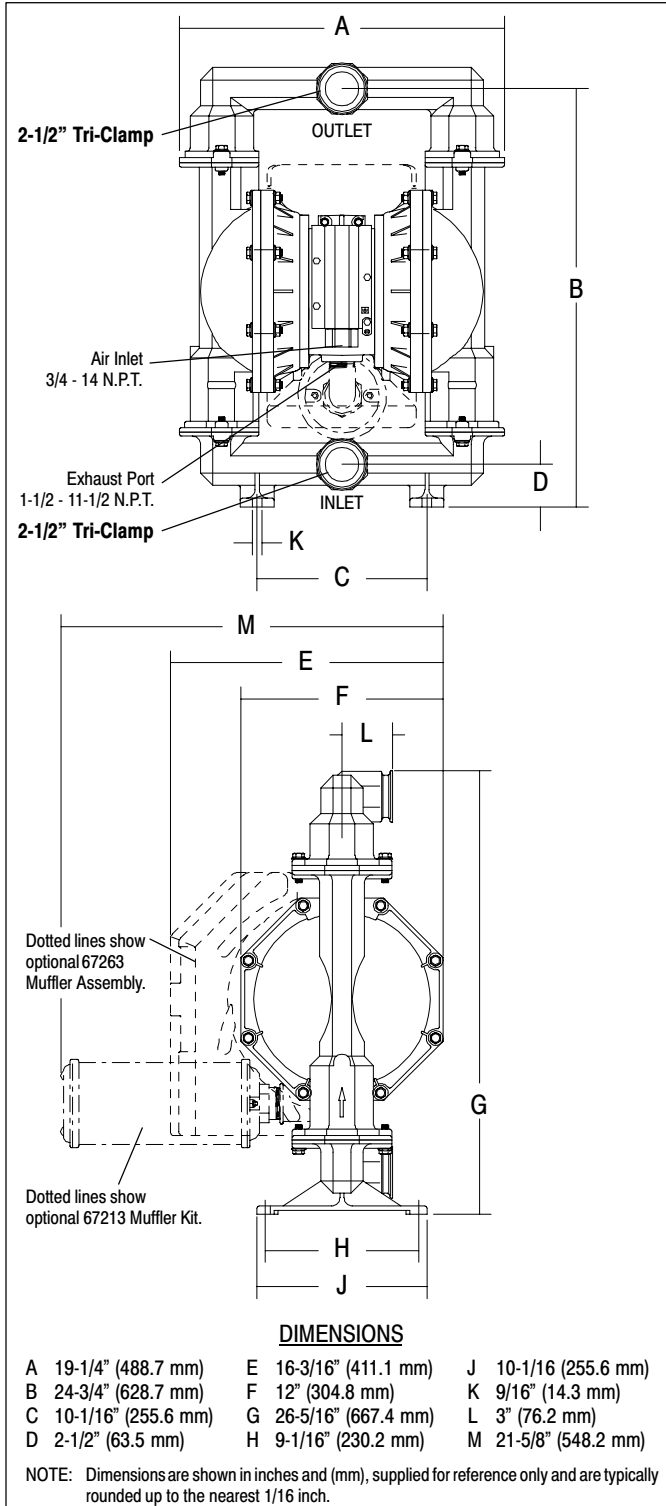

SPECIFICATIONS

CONSTRUCTION

Model Series	PM20X-CSS-XXX-A02
Pump Type	Metallic, Air Operated, Double Diaphragm
Ratio	1:1
Material Inlet / Outlet	2-1/2" Tri-Clamp
Air Inlet (female)	3/4 - 14 N.P.T.
Air Exhaust (female)	1-1/2 - 11-1/2 N.P.T.
Weight . (PM20S-CSS-XXX-A02)	184 lbs (83.5 kgs)
(PM20A-CSS-XXX-A02)	151.6 lbs (68.8 kgs)
Air Section Service Kit	637302
Fluid Section Service Kit	637309-XX

PM20X-CSS-X -A02

637309 -

Diaphragm Material
Ball Material

EXAMPLE: Model#PM20S-CSS-SAA-A02
Fluid Section Service Kit is 637309-AA

PERFORMANCE

Air Inlet Pressure Range	20 - 120 p.s.i. (1.4 - 8.3 bar)
Maximum Material Inlet Pressure	10 p.s.i. (0.69 bar)
Fluid Outlet Pressure Range	20 - 120 p.s.i. (1.4 - 8.3 bar)
Maximum Flow Rate (flooded inlet)	170 g.p.m. (644 l.p.m.)
Maximum Particle Size	1/4" dia. (6.4 mm)
Maximum Temperature Limits	200°F (93°C)
Displacement / Cycle @ 100 p.s.i.	1.4 gal. (5.3 liters)
Noise Level @ 70 p.s.i. - 60 c.p.m.①	85.0 db(A)②

Notes:

- ① Tested with 67263 muffer assembly installed.
- ② The pump sound pressure level has been updated to an Equivalent Continuous Sound Level (L_{Aeq}) to meet the intent of ANSI S1. 13-1971, CAGI-PNEUROP S5.1 using four microphone locations.

ACCESSORIES:

- 66312 Air line Connection Kit
- 67213 Muffer Kit
- 67263 Continuous Muffer
- 94117 Int. Muffer



PERFORMANCE CURVES

PM20X-CSS-XXX-A02 2" METALLIC DIAPHRAGM PUMP

